

# AMERICAN RANGE

QUALITY COMMERCIAL COOKING EQUIPMENT

## ARSM HEAVY DUTY CUSTOM SALAMANDER BROILER RESTAURANT SERIES

### STANDARD FEATURES

- Heavy gauge insulated body.
- All Stainless Steel front & sides.
- Stainless Steel standing pilot for instant ignition of burners.
- Gas fired 35,000 BTU/hr. infrared burner provides instant, even heating.
- Adjustable gas valve.
- Grid rack assembly rolls out for ease of loading and unloading.
- Large capacity drain pan.
- Broiler grid can be easily removed for cleaning.
- One year limited warranty, parts and labor.



ARSM-36

### OPTIONAL FEATURES

- Mounting assemblies available for wall mounting.
- Mounting assemblies available for range-mounting. (Check with factory for details).
- Counter-mount legs and leg mounting channels are optional.

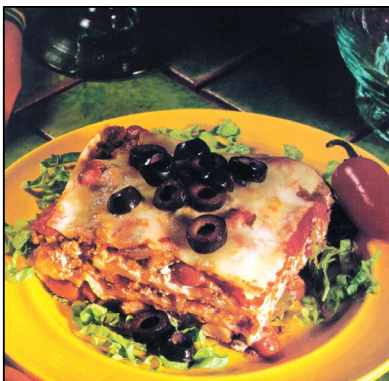

American Range Heavy Duty Salamander Broiler is innovatively engineered for optimum performance and long lasting durability. The modern design features infrared burner technology that provides complete coverage of a large cooking area. Four rack positions and a well balanced rack lift mechanism provide superb flexibility of heat control for the discriminating operator. The infrared broiler provides instant, even heating for the perfect preparation of steaks, fish, and lobster. Excels in the preparation of melted cheese dishes such as Mexican and Italian specialties. Due to its versatility, browning and finishing a wide range of foods, such as au gratin dishes, garlic toast, and omelettes, are a breeze. The stainless steel finish of the Salamander broiler, coupled with its elegant styling and easy to reach controls and competitive pricing, makes the ARSM Salamander the best value for your budget. Look to American Range for innovation, reliable performance and quality, now and for all your future needs.

# ARSM SALAMANDER BROILER

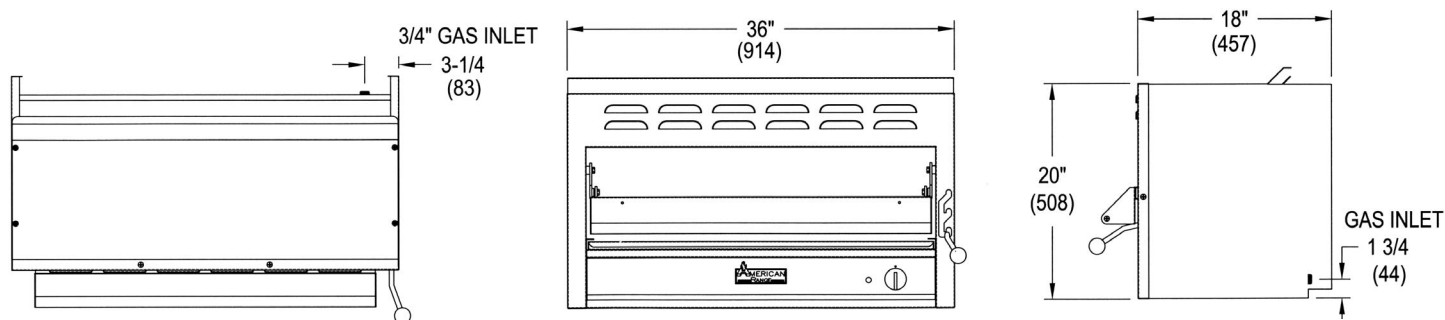

Model	Width	Depth	Height	No. of Burners	Total BTU	KW	Shipping Weight	Lbs.	Kg.
ARSM-24	24"	18"	21-1/2"	1	25,000	7		175	80
ARSM-36	36"	18"	21-1/2"	1	35,000	10		200	91

## STANDARD FEATURES

- Heavy gauge insulated body.
- All Stainless Steel front, sides and top.
- Standing pilot for instant ignition.
- Gas fired 35,000 BTU/hr. infrared burner provides instant, even heating.
- Adjustable gas valve.
- Grid rack assembly rolls out for ease of loading and unloading.
- Large capacity drain pan.
- Broiler grid can be easily removed for cleaning.
- Counter-mount legs and leg mounting channels are optional.
- One year limited warranty, parts and labor.

## OPTIONAL FEATURES

- Mounting assemblies for wall mounting.
- Range Mount Kit - May be mounted on most AR-Restaurant range models. For all models except 36" (914) series, must be ordered from factory with mounting channels. Call the factory for details.
- Counter Mount Kit - May be counter-mounted with 4" (152) legs and available leg mounting brackets.

**GAS SUPPLY:** 3/4" NPT Gas inlet. Manifold pressure is 5.0"W.C. for natural gas or 10.0"W.C. for propane gas. Specify type of gas and altitude if over 2000 feet.

**CLEARANCES:** For use only on non-combustible floors. Legs or casters are required, or 2" (51) overhang is required when curb mounted. Clearance from non-combustible walls is 0". When unit is placed next to combustible walls, clearances must exceed 12" (305) on sides, and 4" (102) from rear. Radiant broilers for non-combustible locations only.

American Range is a quality manufacturer of commercial cooking equipment. Because of continuing product improvements these specifications are subject to change without prior notice.